

TSA 100 x 315

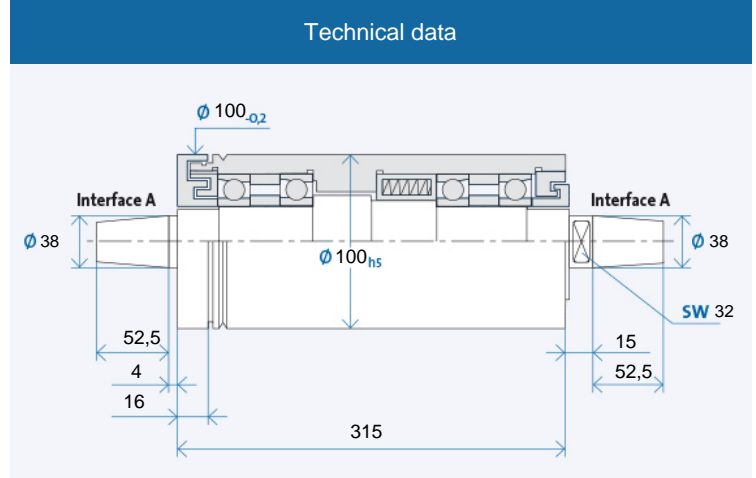
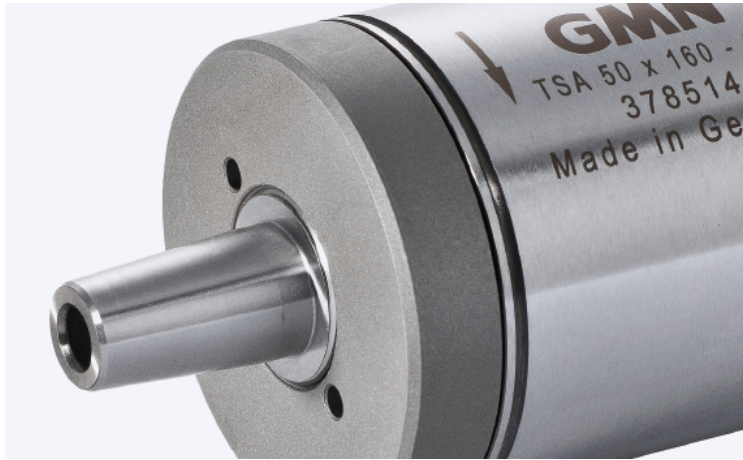

Maximum speed n_{max} [min⁻¹]* for bearing types:

Steel (steel)	15000
Hybrid (optional)	20000

* without tool

Ordering information: TSA 100 x 315 R is for clockwise, L for counter-clockwise

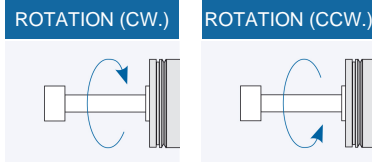

Accessories

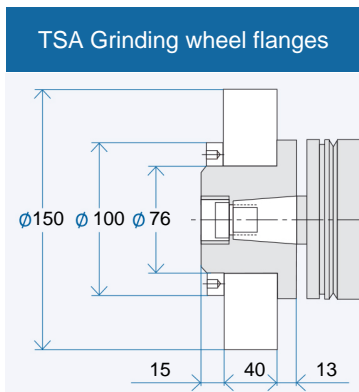

Ordering information flange: AX₁/X₂/X₃
 X₁: Interface: 07/08/...
 X₂: Flange style: MO/MS
 X₃: Wheel: K = Corundum grinding wheel
 D = Diamond or CBN grinding wheel
 Puller for flange: AX₁/X₂
 Balancing quill for flange: AX₁

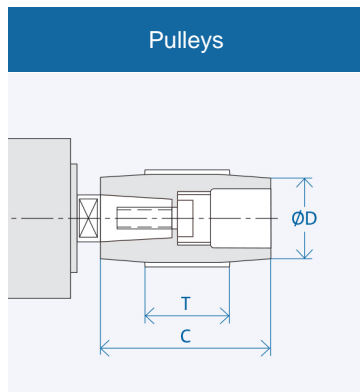

Interface	Dimensions [mm]		
	D	C	T
A 38	50	80	60
	63	80	60
	160	80	60

Ordering information pulley: AX₁-X₂
 X₁: Interface: 07/08/...
 X₂: Figure from column D
 Puller for pulley: AX₁/...

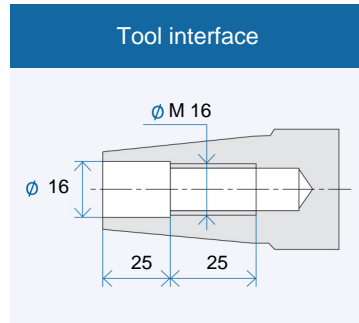

Tool interface: taper 1 : 7,5 nominal value, included angle acc. to GMN precision standards

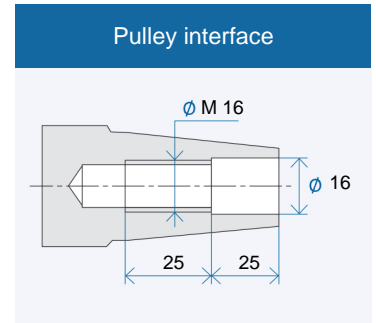

Pulley interface: taper 1 : 7,5 nominal value, included angle acc. to GMN precision standards

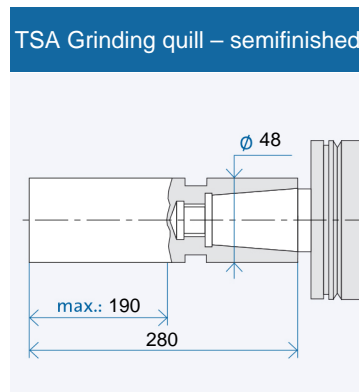

Ordering information semifinished: AX₁
 X₁: Interface 10/13/...