

Spindle ball bearing HY SM 61915 C TA P4+

16.07.2024



Components

Bearing designation:	HY SM 61915 C TA
Bearing design:	SM
Series / size:	61915
Ball material:	Ceramic
Cage:	TA
Seal:	2RZ upon request
Precision:	P4+
Main dimensions [d x D x B]:	75 x 105 x 16 mm

Load data

Static load capacity	C_{0r} : 16100 N
Dynamic load capacity	C_r : 21400 N
Fatigue load limit	C_U : 610 N
Speed limit	n_{grease} : 21000 1/min
Speed limit	n_{oil} : 28000 1/min
Light preload	L: 110 N
Axial rigidity	C_{ax} : 88 N/ μ m
Medium preload	M: 320 N
Axial rigidity	C_{ax} : 130 N/ μ m
Heavy preload	S: 640 N
Axial rigidity	C_{ax} : 171 N/ μ m
Spring preload	Ff: 850 N (for n_{max})

Geometrical Data

Bore diameter	d: 75 mm	Oiling nozzle position	d_f : 87.4 mm
Outer diameter	D: 105 mm	Pitch circle diameter	d_m : 90 mm
Width of single bearing	B: 16 mm	Inner diameter of outer ring	D_1 : 95.3 mm
Ball diameter	D_w : 8.731 mm	Undercut of associated component	$r_{a \max}$: 0.6 mm
Number of balls	Z: 25	Undercut of associated component (open side)	$r_{b \max}$: 0.3 mm
Chamfer (min)	$r_{1,2 \min}$: 0.6 mm	Abutment diameter inner ring	$d_{a,b \min}$: 79.6 mm
Chamfer (min), open side	$r_{3,4 \min}$: 0.3 mm	Abutment diameter outer ring	$D_{a,b \max}$: 101 mm
Outer diameter of inner ring	d_1 : 84.7 mm	Inner diameter of outer ring (open side)	D_2 : 98.9 mm
Outer diameter of inner ring (open side)	d_2 : -	Bearing weight	m: 0.31 kg
		Contact angle	Alpha 0: 19°

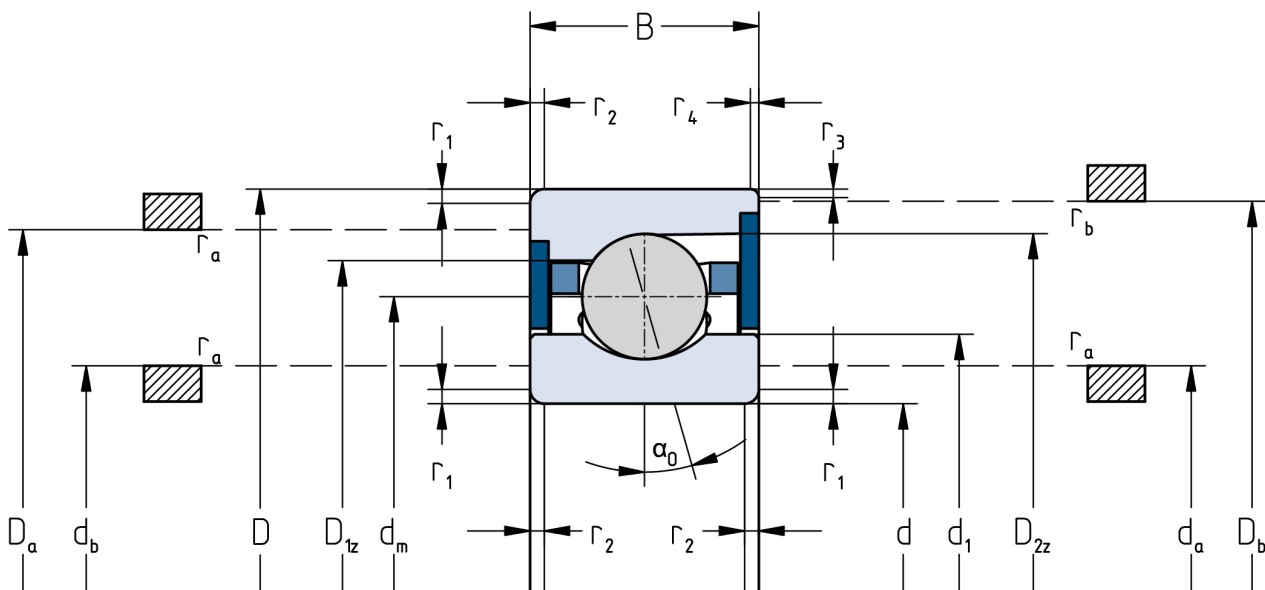

The given speed limits apply to individual bearings with spring preload. Correction factors must be considered for all properties which deviate from this.